

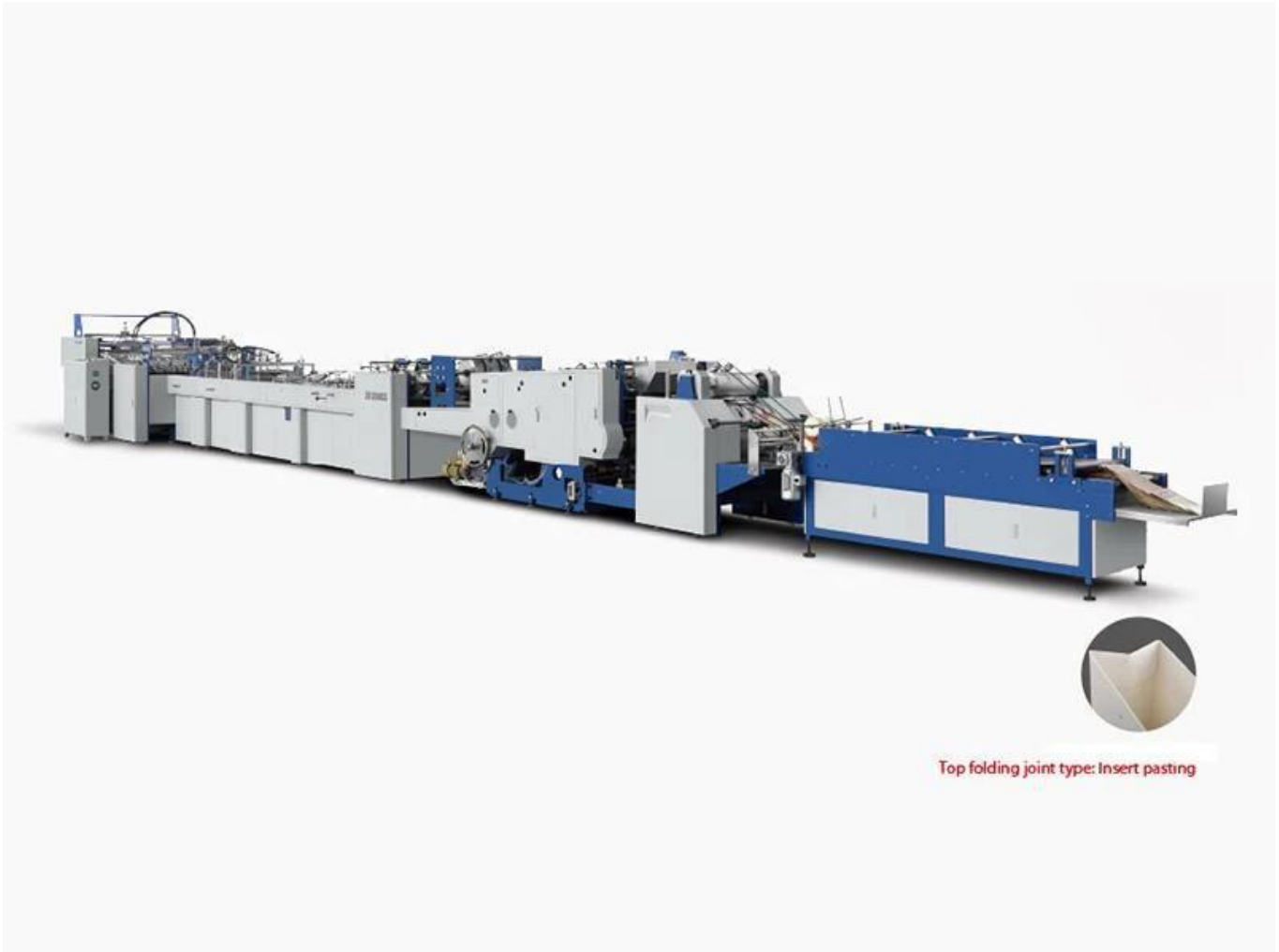

EX-1200CS-430 Sheet-Feeding Paper Bag Making Machine



EX1200CS-430 Sheet-feeding Paper Bag Making Machine folding parts:

EX1200C S-430 fully automatic sheet-feeding paper bag making machine (Adopt Italy technology) is suitable for the mass bag production, it is the first choice of medium and top-grade handbag device. The product adopts mechanical, electricity, light, gas integration technology, setting a number of its proprietary technology, can one-time leaflet after press and creased paper, automatic paper feeding, positioning, tope folding, tube folding, bottom folding and gluing to compaction output. The variable speed drive technology, combined with the system of vertical and horizontal creasing, bottom folding realizes trackless bag molding process. using the PLC programmable control, frequency control technology to realize the integral multi-dimensional control, more centralized control and single point remote control operating system. with characteristics of good quality and high efficiency, its technology ranks leading level in domestic products.



1), Working Procedure (finished paper bag tube folding and top edge fold)

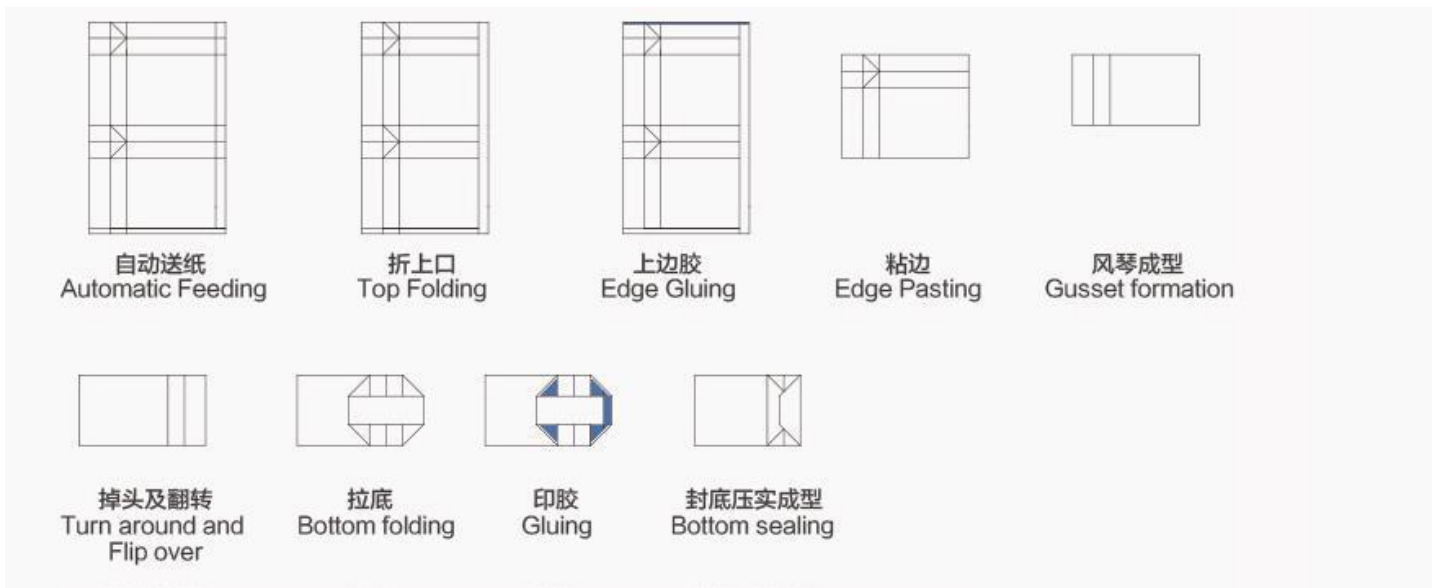

Main Technical Parameters

Max. sheet (LX W)	1200x600mm
Min. sheet (LX W)	560x300mm
Top folding sheet weight	190g-300g/m ²
Traditional sheet weight	120g-300g/m ²
Bottom Width	90-180mm
Bag Width	180-430mm
Top Folding Deepxh	30-70mm
Total Power	20kw
Machine Size	14800x2400x1800mm
Speed	50-80bags/min
Total Weight	12T
Glue Type	Water soluble cold glue (hot-melt glue)



Applicable Paper

	A	B	C	D	E
Max. Size	1200	600	180	430	500
Min. Size	560	300	90	180	250

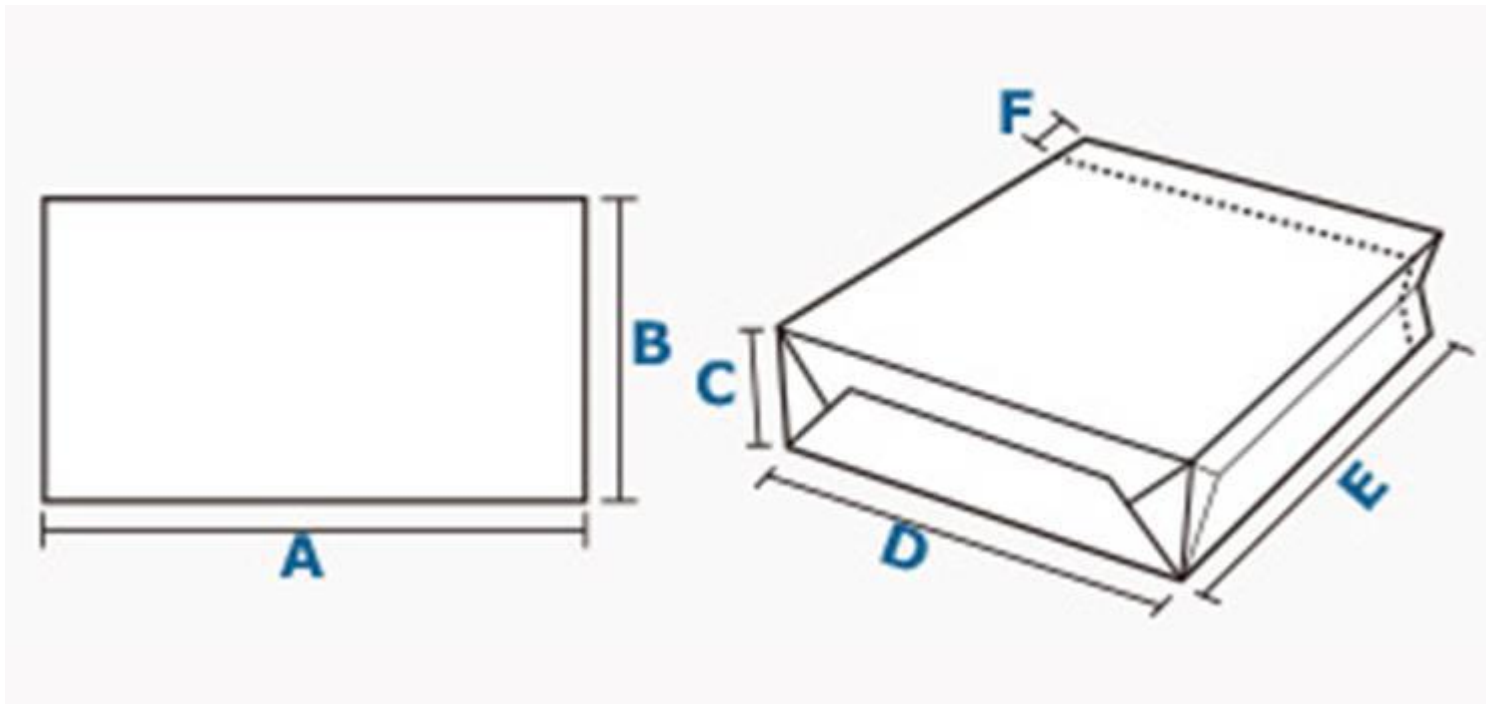

Suitable Paper: Kraft paper, art paper
(including film laminated paper) paper need pre-creasing
80mm bag bottom width is customizable

Machine Configuration



1. Feeder: enhanced press tack paper feeder to realize non stop paper feeding, greatly save the time to load and adjust raw paper.
2. Front and side guides positioning system
3. Top folding system
4. Both water soluble cold glue and hot melt glue
5. Formation version making gusset system
6. Screw rod to adjust bottom clip system
7. Bottom catch bag roller paper bag fall down alert system
8. Automatic collection system: Automatic counting, convenient to collect bags.