



EX1200B Sheet-Feeding Bag Tube Forming Machine



Product Application

EX1200B semi-automatic paper bag making machine is suitable for the mass production of special paper and different types of polished and laminated paper (already creased sheet of paper as raw materials). It is the first equipment choice for manufacturing high-grade and luxury handbags. The paper automatic delivery by feeder (frequency control), automatic positioning by guide and line aligning system, automatic pasting by roll glue device, top folding or without automatic gusset forming, press bag output.

Suitable paper

	A	B	C	D	E
Max. Size	1200	600	180	430	600
Min. Size	560	300	90	180	300

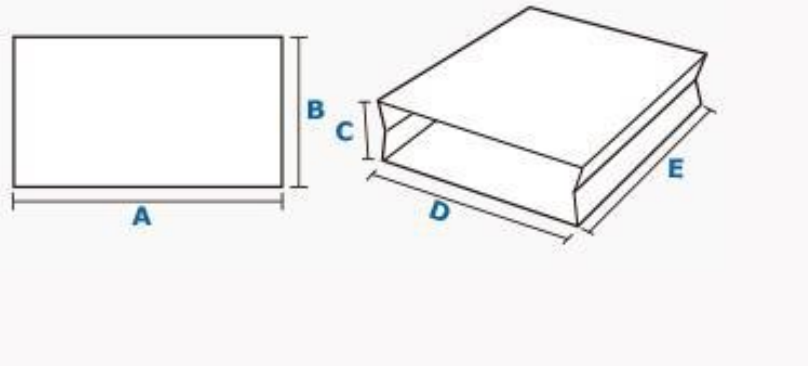

Suitable Paper: Kraft paper, art paper
(including film laminated paper)
80mm bag bottom width is customizable

Technical parameters:

Max. sheet (L x W)	1200x600mm
Min. sheet (L x W)	560x300mm
Sheet weight	100g-350g/m ²
Bottom Width	90-180mm ²
Total power	10kw
Machine size	10100x2400x1800mm
Speed	60-80bags/min
Total weight	6T
Glue Type	Water soluble cold glue



Technological process:

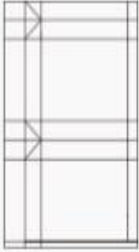

自动送纸
Automatic Feeding

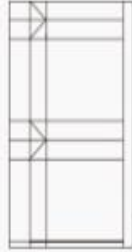

折上口(不带折上口配置
的机器无此功能)
Top Folding
(unavailable for machine
without this function)

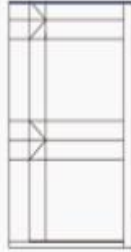

上边胶
Edge Gluing

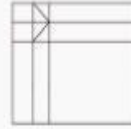

粘边
Edge Pasting



风琴成型
Gusset formation