



SHANGHAI EX. EXPORT INTERNATIONAL INDUSTRY CO., LTD

ZYH 660D 780D Combi-Folding Machine



This machine is a fully automatic combi-folding machine in bisection. The first folding section of type ZYH660D is 4 pieces of railing beards, while the first folding section of ZYH660D is 2 pieces. It could work with paper feeders of FD accumulation type or RD ring wrap type. ZYH660D can carry out folds as four-time parallel type, organ type and reel type.

ZYH660D could perform two-time parallel folding with paper punching and creasing at the same time. Other traits: PLC controlled electric system. Frequency and speed-controlled system. Automatic stopping in case of paper jamming and double-paper feeding. Up to world-level quality: Easy and safe to operate / high-precision/stable. It's a good choice for large or medium-sized printing enterprises.



Technical Parameters

Model	ZYH660D	ZYH780D
Foldable max sheet size	660x1040mm	780x1160mm
Foldable min sheet size	150x200mm	150x200mm
Foldable sheet rotation range	40–200g/m ²	40–200g/m ²
Folding & rolling max line speed	150m/min	150m/min
Clasp knife max speed	150strokes/min	150strokes/min
Total power	5.2kw	7kw
Packing Size	主机	2070x1630x1470mm
	副机	2920x1465x1610mm
Packing Weight	2370kg	2770kg

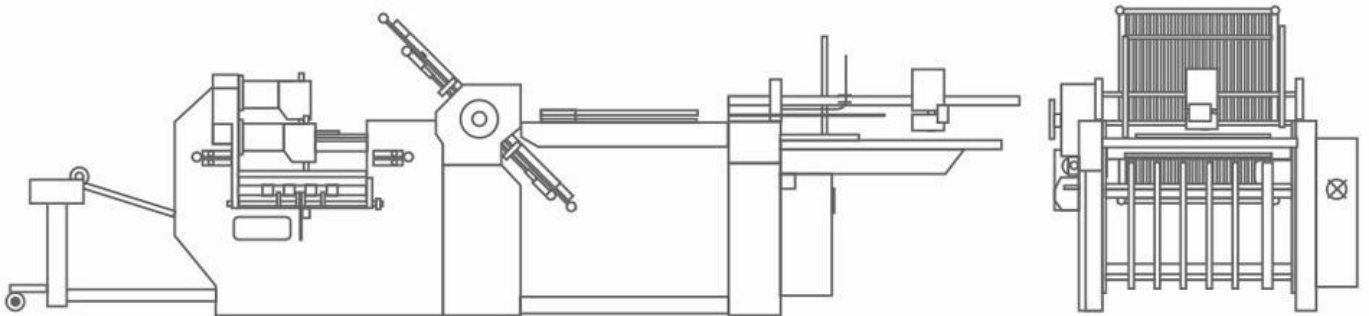

胶辊采用国际先进技术压注
Cast Rubber Roller Of International
Advanced Technology

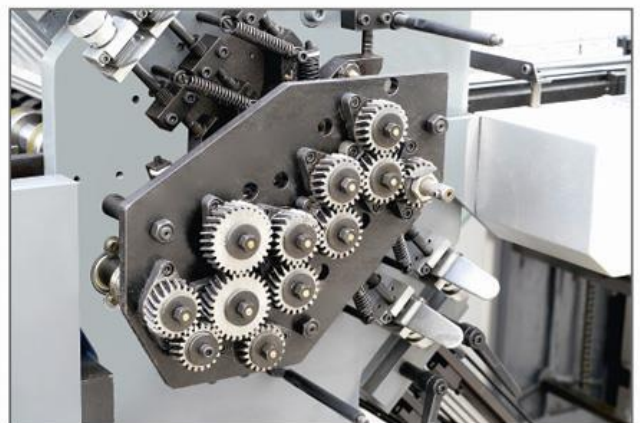

高精度的十字联轴器转动调整
High-precision Spindle Coupler
Transmission

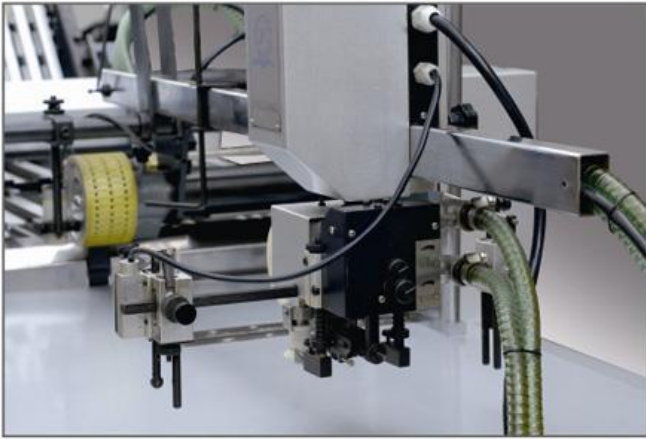

高性能飞达
High-Performance Motor



ZYH780D单机带正反折功能
ZYH780D with positive
and negative folding function

工艺流程 **Process**

